

Specification Sheet

Scheda tecnica

EBF-03

Classification <i>Tipo di prodotto</i>	Blast chiller / Abbattitore	Cooling Method <i>Tipo refrigerazione</i>	Ventilated / Ventilato
Doors <i>Porte</i>	1	Defrost Method <i>Sbrinamento</i>	Hot Gas Defrost / Gas Caldo
Temperature (°C) <i>Temperatura</i>	3°C/-18°C	Refrigerant <i>Gas refrigerante</i>	R290 (Propane) - GWP 3
Climate temperature <i>Temperatura ambiente</i>	30°C 55%	Refrigerant Amount (g) <i>Quantità gas</i>	150
Volume (L) <i>Capacità</i>	74	Climate type <i>Classe climatica</i>	4
Thermostat <i>Termostato</i>	Dixell/Carel	Exterior Dimensions (body) (mm) <i>Dimensioni corpo macchina</i>	755x832x552
Shelf QTY <i>Quantità Ripiani</i>	-	Height with Leg (mm) <i>Altezza inclusi piedi regolabili</i>	581
Shelf Dimensions (mm) <i>Dimensione ripiani</i>	-	Height with Castor (mm) <i>Altezza incluse ruote</i>	-
Loading capacity per shelf (kg) <i>Carico massimo per griglia</i>	-	Interior Dimensions (mm) <i>Dimensioni interne</i>	410×680×256
Insulation thickness (mm) <i>Coibentazione</i>	70	Wood Packing Dimensions (mm) <i>Dimensioni imballo</i>	905×822×730
Foaming Material <i>Materiale coibentante</i>	CSH10	Net Weight (kg) <i>Peso netto</i>	72
LED Lights <i>Luci LED</i>	NO	Gross Weight (kg) <i>Peso lordo</i>	97
Power (W) <i>Potenza</i>	1100	Voltage (V/Hz/Ph) <i>Voltaggio</i>	220-240/50/1
fast cooling performance (CHILL) <i>Performance ciclo positivo</i>	10kg(+65°C/+10°C) in 90min	Compressor Brand <i>Compressore</i>	EMBRACO
fast freezing performance (FREEZE) <i>performance ciclo negativo</i>	5kg(+65°C/-18°C) in 270min	Compressor Model <i>Modello compressore</i>	NEK2150U
Rated Current (A) <i>Corrente nominale</i>	6	Compressor Power (hp) <i>Potenza compressore</i>	1/2+
Refrigeration output per compressor (W) <i>Resa frigorifera per compressore</i>	evap.-23.3°C, cond.54.4°C: 596W	Material <i>Materiale</i>	Internal: SS304 External: SS201

1

2

3

4

5

6

A

B

C

D

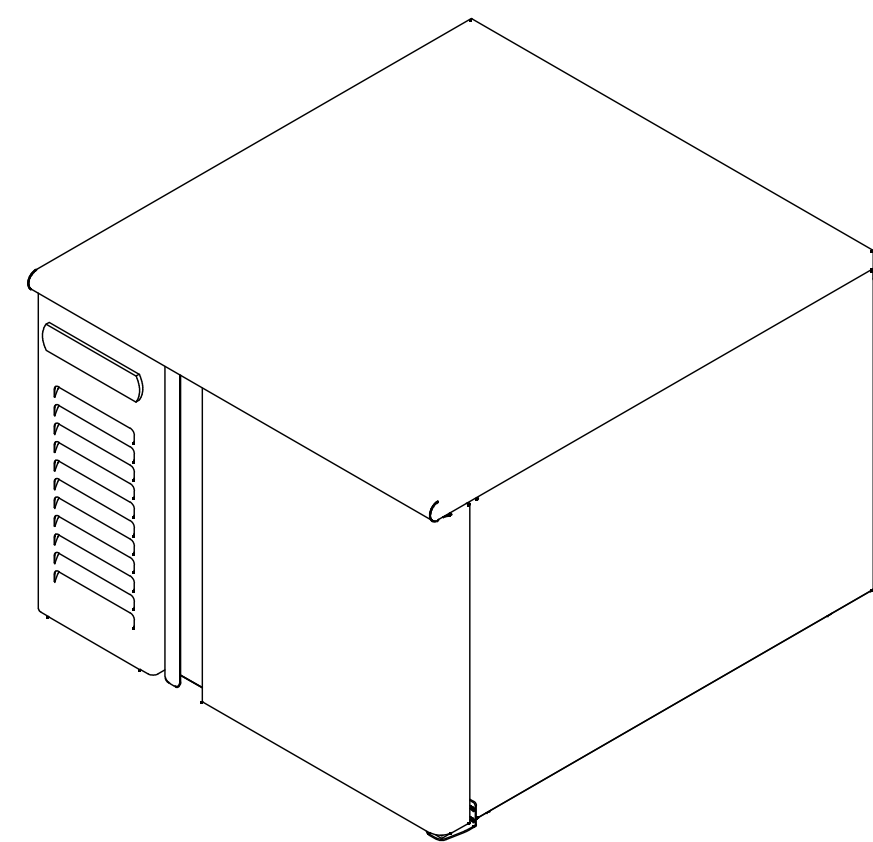
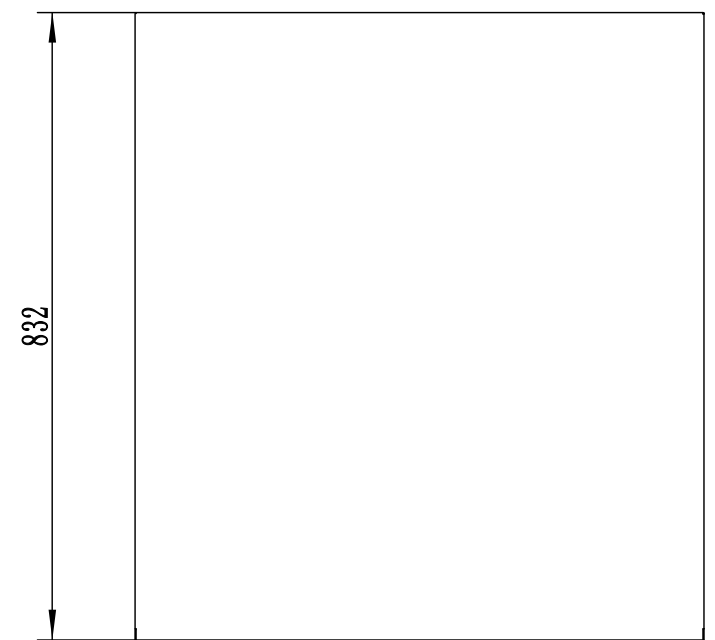
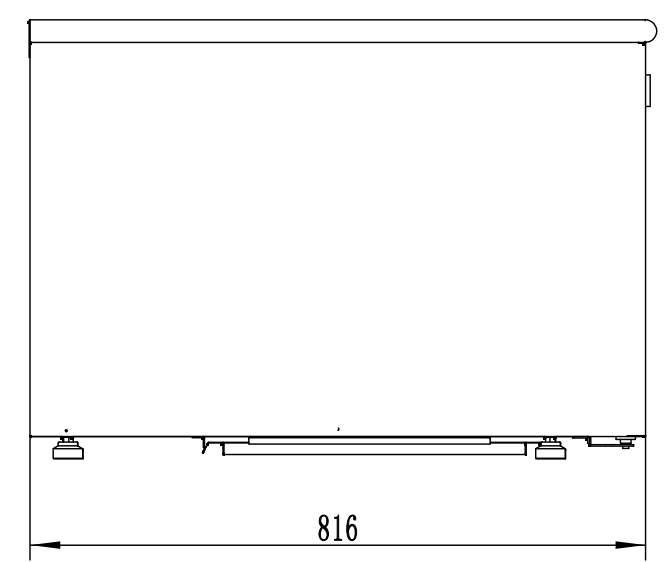
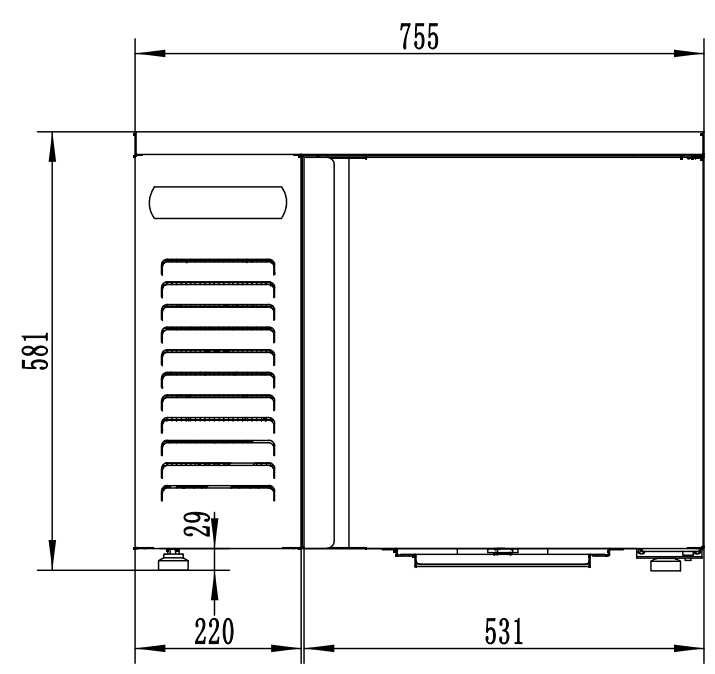

						 物料编号:EBF-03				
									展开尺寸:	
标记	处数	分区	更改文件号	签名	年、月、日	程序编号:			3盘速冻柜	
设计			标准化			阶段标记	重量 (KG)	比例		
审核								1:10	三视图	
工艺			批准			共	张	第		
						版本号:	a1			

1

2

3

4

5

6