

FM — Chamber fan motor	CP — Core probe	CW — Chimney Switch	TS — Safety thermostat
PW — Power Switch	DS — Display screen	LED — Led light	EL — Solenoid valve
TF — Transformer	MS — Chamber fan motor encoder	CM — Chimney motor	IT — Contactor
CA — Capacitor	LW — Low pressure Switch	MP — Solenoid pump	RC — Heating Element
TP — Temperature probe	DW — Door Switch	CF — cooling fan motor	

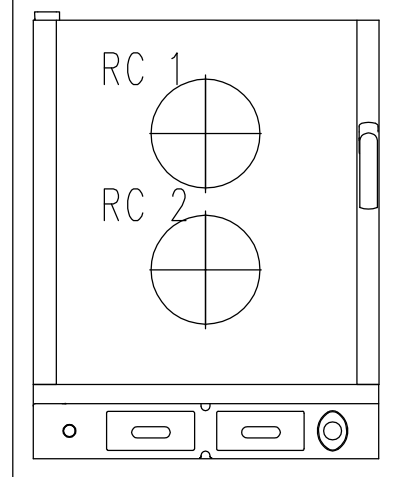
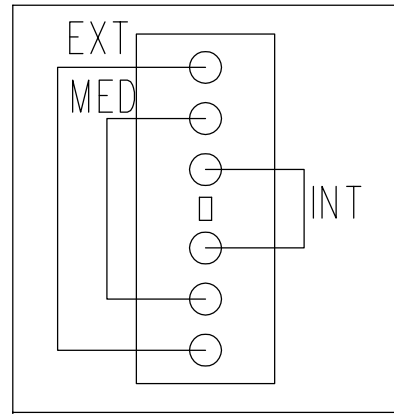
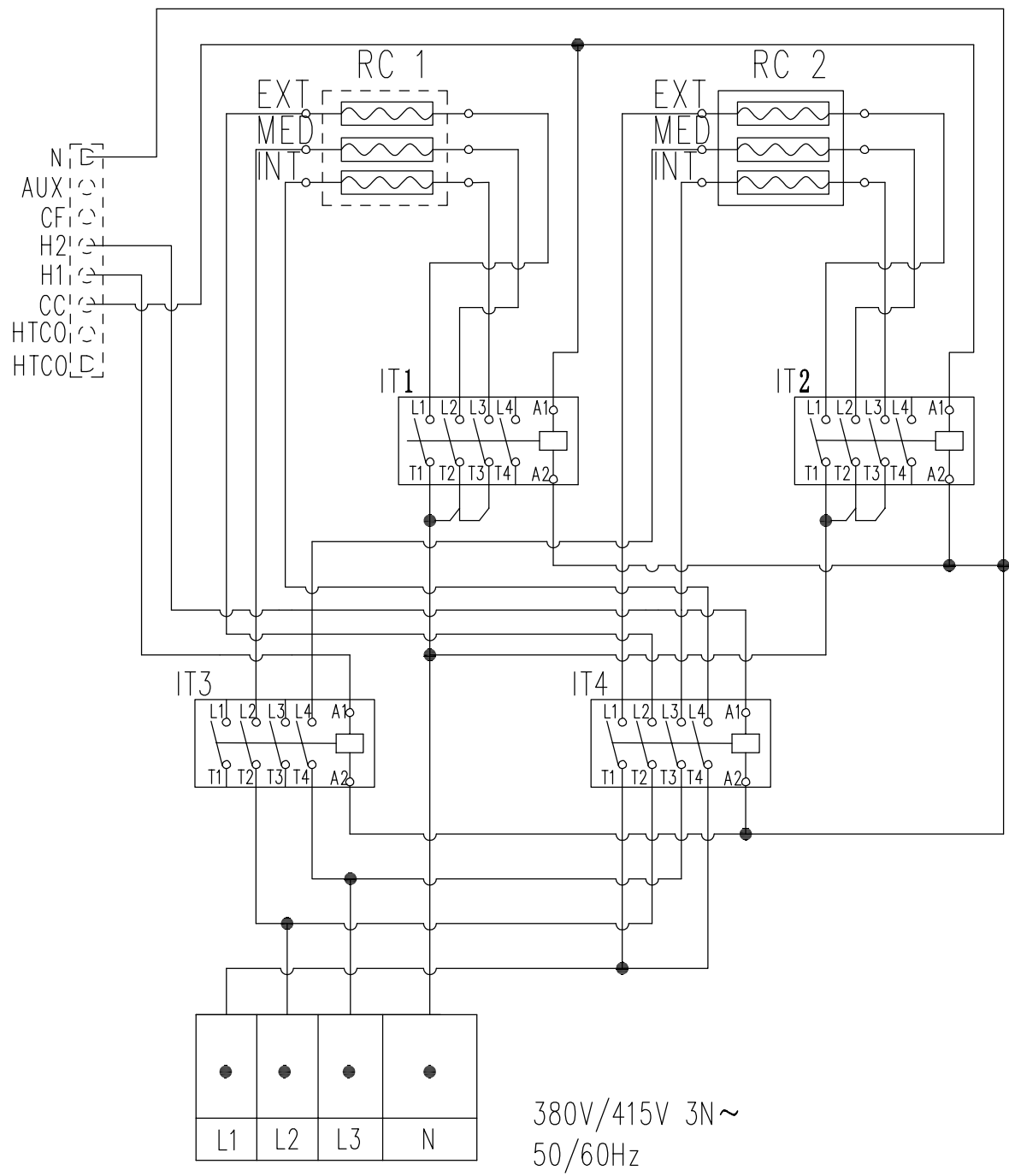

EPC-1011E2

380V/415V 3N~
50/60Hz